

# 加工指南 Processing instructions

## 爱格双饰面板 EGGER Decorative Boards 芯板 EGGER Core Boards



### 目录 Table of contents

目录  
Table of contents ..... 1

1. 产品描述 Product description ..... 3

2. 安全 Safety ..... 3

    2.1. 一般准则 General ..... 3

    2.2. 安全生产 Work safety ..... 4

    2.3. 甲醛 Formaldehyde ..... 4

    2.4. 粉尘引起的健康风险 Health hazard due to dust ..... 4

    2.5. 火灾和爆炸风险 Fire and explosion hazard ..... 4

    2.6. 三聚氰胺树脂 Melamine resins ..... 4

3. 储存 Storage ..... 5

    3.1. 一般说明 General instructions ..... 5

    3.2. 平衡调节 Conditioning ..... 5

    3.3. 水平储存 Horizontal storage ..... 6

    3.4. 垂直储存 Vertical storage ..... 6

    3.5. 操作 Handling ..... 7

4. 刀具推荐 Tool recommendations ..... 8

5. 加工 Processing ..... 8

    5.1. 板材膨胀 Board expansion ..... 8

    5.2. 切口 Cut-outs ..... 9



5.3.	封边 Edging .....	9
5.4.	切口/钻孔的密封 Sealing of cut-outs/drill holes .....	10
5.5.	粘合 Bonding .....	11
5.5.1.	两块板的表面粘合 Surface bonding of two boards .....	11
5.5.2.	和其它材料间的粘合 Bonding with other materials .....	11
5.6.	螺钉连接 Screw connection .....	11
5.7.	平头螺钉连接 Flat screw connection .....	12
5.7.1.	定点 Fixed points .....	13
5.7.2.	浮点 Sliding points .....	13
5.8.	水平接缝和板接缝 Horizontal joints and board joints .....	14
5.9.	上漆 Lacquering .....	15
5.10.	固定件 Fittings .....	15
5.11.	素板深加工 Further processing of the raw board .....	16
6.	应用 Applications .....	16
6.1.	墙板 Wall cladding .....	16
6.1.1.	底部结构和背面通风 Substructure and rear ventilation.....	16
6.1.2.	可视机械固定 visible mechanical fastening .....	17
6.1.3.	隐形机械固定 Concealed mechanical fastening.....	17
6.1.4.	隐形施胶固定 Non-visible glued fastening .....	18
6.2.	家具门板 Furniture doors .....	19
7.	推荐的清洁方法和用量 Recommendations for cleaning and use .....	20
8.	废物处理 Disposal .....	20



## 1. 产品描述 Product description

**爱格双饰面板或爱格双饰面中密度板** (依照欧洲标准 EN 14322) 由木质材料组成, 两面覆盖浸渍装饰纸。适用于水平方向和垂直方向的 (如家具门板及面板、搁板、衣柜或墙板) 家具及室内设计。

**EGGER Decorative Particleboards or MDF** (according to EN 14322) consist of wood-based materials that are covered on both sides with impregnated decorative paper. They are used horizontally and vertically in furniture and interior design, such as for fronts, shelves, wardrobes or wall cladding.

**爱格多层表面结构双饰面板或爱格多层表面结构双饰面中密度板**由于厚度高达 1mm 的特殊多层结构, 所以能够满足日趋增加的抗冲击性能需求。多层结构具有较高的抗弯曲强度和稳定性, 因此非常适合宽度跨度需要增加的结构。如果需要, 还可额外增加耐磨层 (HR) 用于增加产品表面的耐磨性能。

**EGGER Decorative Multilayer Particleboards or MDF** meet increased requirements for impact resistance thanks to special multi-layer construction up to 1 mm thickness. Multi-layer constructions have high bending strength and stability, and are therefore well suited for constructions with increased span widths. If desired, an additional overlay (HR) can be integrated for increased wear resistance.

**爱格阻燃双饰面板**是阻燃级的双饰面刨花板和中密度板, 适用于对防火性能额外需求的区域。

**EGGER Decorative Flammex Flame Retardant Boards** are flame-retardant, faced chipboards and MDF with increased requirements for fire behaviour.

**爱格刨花板**由坚实的芯层和精细的表层组成。此种三层结构的板材在家具及室内设计上能提供较广范围的应用。此外, 精细的表面也是不同涂层的理想选择。

**EGGER Raw Particleboards** consist of a sturdy core layer and fine outer layers. This three-layer structure offers a wide range of applications in furniture and interior design. In addition, the surface is ideal for different coatings.

**中密度纤维板是一种中密度的纤维板**由于其较高的横向拉伸强度和边缘稳定性, 所以非常适合在有较高要求的家具和室内设计上进行应用。

**EGGER Raw MDF** are medium-density fibreboards that are very well suited for use in demanding furniture and interior design thanks to their high transverse tensile strength and edge stability.

**薄型刨花板**是一种最小厚度为 3mm 的超薄刨花板。表面以精细和质轻为特征且适合用作超轻板, 抽屉底部, 门板面层或背层的面板。

**EGGER Thin Raw Particleboards** are extra-thin chipboards available from a thickness of 3 mm. They are characterised by their fine and light surface appearance and are suitable for use as top layers for lightweight boards, drawer bottoms, door skins or rear walls.

**薄型中密度纤维板**是一种薄型的、中密度纤维板。由于其结构均匀、易于加工。其表面规则、精细且表面可用防火板、油漆、薄膜和单板进行装饰处理。

**EGGER Thin Raw MDF** are thin, medium-density fibreboards that are easy to process thanks to their homogeneous structure. Its surface is regular and fine-grained, and can be coated with laminate, lacquer, finish foil and veneer.

**爱格薄型饰面板或爱格薄型饰面中密度板**是一种单面饰面的板材, 尤其适合作为室内门生产的装饰板和可见的家具背板。

**EGGER Decorative Single Sided Thin Particleboards or EGGER Decorative Single Sided Thin MDF** are boards finished on one side with a coating and are particularly suitable as a decorative board in interior door production and for visible furniture rear walls.

## 2. 安全 Safety

### 2.1. 一般准则 General

在开始加工处理爱格木质产品之前, 应当知晓适用的加工刀具、加工信息和安全需求。

The available tools, the processing instructions and the safety requirements should be known at the start of working with EGGER wood-based materials.

板材可能仅仅只在规定的技术限制值和性能的框架范围内使用。板材的技术性能和标准分类在技术数据表中列出，请在我们公司网站 [www.egger.com](http://www.egger.com) 中查找。超出这些值的使用需要对板材进行单独测试

The boards may only be used within the scope of the technical limit values and properties. The technical properties and standard classifications of the boards are listed in the technical data sheets, which can be found on our website: [www.egger.com](http://www.egger.com). Usage outside these values requires separate testing of the boards.

当加工爱格板材时仅能使用合适的机械设备和刀具。万一有疑问，应咨询相应的设备商或刀具商。当使用这些板材时，应使用合适的紧固件。如有疑问，请咨询紧固件制造商。

Only use suitable machines and tools for processing the boards. In case of doubt, consult the respective machine or tool manufacturer. When using the boards, use suitable fastening materials. In case of doubt, consult the manufacturer of the fastening materials.

关于爱格木质材料的耐温性，爱格双饰面板产品的耐高温性根据热暴露时间长短而有所不同。对于长时间持续的热暴露，可以适应的最高温度为 50°C。在超过 50°C 温度下连续暴露时，可能会导致产品表面出现裂纹。在安装会产生热量的技术设备时（如笔记本电脑等），我们建议须在热源与双饰面板表面间保持合适距离，以避免产生热量累积，并且能够相应地进行散热。

With regard to the temperature resistance of EGGER wood-based materials, there is a basic distinction between long-term and short-term heat exposure. Temperatures of up to 50 °C are permissible for continuous heat exposure. We expressly point out that continuous temperature exposure > 50 °C can lead to cracks in Decorative Boards surfaces. When using technical equipment that emits heat, such as laptops, we recommend leaving sufficient distance between the heat source and the surface to avoid heat accumulation and to be able to dissipate the temperature accordingly.

由于木材是一种吸湿性材料，其性能会因暴露于水分和变化的环境湿度而改变。当在湿度不断增加或与水或其他液体接触的区域使用木质材料时，应采取适当的预防措施，这些措施已经在以下文件中进行了描述。有关该板材的推荐应用领域以及在干燥和潮湿条件下使用类别的更多详细信息，请参阅我们网站上的技术数据表: [www.egger.com](http://www.egger.com)。特别是对于素板，重要的是要确保它们不与水分进行接触。

As wood is a hygroscopic material, its properties change due to exposure to moisture and changes in ambient humidity. When using wood-based materials in areas with increased humidity or in contact with water or other liquids, appropriate precautions should be taken, which are explained in more detail in the following document. For more detailed information on the recommended areas of application for the boards and the class of use with regard to use in dry and humid conditions, please refer to the technical data sheets on our website: [www.egger.com](http://www.egger.com). Particularly with raw boards, it is important to ensure that they do not come into contact with moisture.

注意！对产品的不当操作可导致影响安全的损坏。这可能导致功能性障碍和健康风险。因此，必须遵循制造商的使用说明。认真、谨慎地处理和加工产品。

ATTENTION! Improper handling of the products can lead to damage that affects safety. This can lead to functional impairments and health risks. It is therefore imperative to follow the manufacturer's instructions for use. Handle and process the products conscientiously and with general caution.

## 2.2. 工作安全 Work safety

作为一般准则，当打开包装扎带和加工期间需配备个人防护设备如手套、防护镜、耳塞、粉尘/呼吸防护具和安全靴。

As a general rule, personal protective equipment (PPE) such as gloves, safety glasses, hearing protection, dust/breathing protection and safety shoes should be worn when opening the packaging straps and during processing.

注意！产品可能很重。在搬运和加工过程中，必须正确紧固，以防止它们掉落、翻倒或滑落。紧固有助于防止产品损坏和人身伤害。如果产品太重，请勿单独提起。

ATTENTION! The products can be heavy. They must be properly fastened during handling and processing to prevent them from falling over, tipping over or slipping. Fastening helps to prevent product damage and injury. Do not lift the products alone if they are too heavy.

注意！当操作和加工产品时，要时刻配戴个人防护设备。

ATTENTION! Always use personal protective equipment (PPE) when handling and processing the products.

### 2.3. 甲醛 Formaldehyde

甲醛释放等级与使用的芯材直接相关。有关您正在使用的芯材的甲醛释放量的信息，请在线参阅爱格芯材技术数据表: [www.egger.com](http://www.egger.com).

Formaldehyde emission classes are directly related to the core material used. For information on the formaldehyde emission of the core material you are using, please refer to the technical data sheets of the core materials, available online: [www.egger.com](http://www.egger.com).

警示！在板材技术性能和标准分类要求外进行加工和应用可能会增加甲醛释放量并因此会产生健康方面的风险。请遵守产品标识的甲醛释放等级。

WARNING! Processing and use outside the technical properties and recommendations of the boards may increase the emission of formaldehyde and thus create health hazards. Please observe the marked emission class for the product.

### 2.4. 粉尘引起的健康风险 Health hazard due to dust

在加工期间可能会产生粉尘。有皮肤致敏和对呼吸道产生影响的风险。根据加工工艺和颗粒大小，尤其当吸入粉尘后，会产生进一步的健康风险。在评估车间风险时必须将粉尘的形成考虑在内。

Dust may be generated during processing. There is a risk of sensitising the skin and respiratory tract. Depending on the processing and the particle size, especially in the case of inhalation of dust, there may be further health hazards. The generation of dust must be taken into account when assessing the risks at the workplace.

尤其在机械加工过程中（如锯切、刨平、铣削），必须使用满足健康和安全法则的有效抽尘系统。如果没有足够的吸尘系统，必须配备合适的呼吸防护设备。

Particularly in the case of machining processes (e.g. sawing, planing, milling), effective extraction must be used in accordance with the applicable occupational health and safety regulations. Suitable breathing protection has to be worn if no adequate extraction system is in place.

### 2.5. 火灾和爆炸风险 Fire and explosion hazard

在加工过程中粉尘的产生会导致火灾和爆炸的风险。必须遵守安全和防火法规。

Dust generated during processing can lead to fire and explosion hazards. Applicable safety and fire protection regulations must be observed.

### 2.6. 三聚氰胺树脂 Melamine resins

我们仅使用在产品表面固化后不会显示任何有害特征且产品预期用途对人体无害的聚合树脂。具体来说，爱格双饰面板中含有的游离三聚氰胺浓度不足以触发如按照欧盟法规 (EC) No. 1907/2006 (REACH) 的额外信息披露义务。此外，爱格双饰面板自然符合欧盟法规 (EU) No. 10/2011 中关于塑性材料和用品可能与食物接触的现有迁移阈值。

Only polymerised resins are used for the production of EGGER wood-based boards, which do not exhibit any hazardous properties after curing in the product as such and are harmless for the intended use of the product. In particular, free melamine as such is not contained in them in a concentration that would trigger additional information obligations, for example under Regulation (EC) No. 1907/2006 (REACH). Furthermore, EGGER wood-based panels naturally comply with the existing migration thresholds according to Regulation (EU) No. 10/2011 on plastic materials and articles intended to come into contact with food.

## 3. 储存 Storage

### 3.1. 一般说明 General instructions

爱格木质产品应在一个封闭且具有稳定温湿度环境 (温度  $T \geq 10^{\circ}\text{C}$ , 相对空气湿度约为 50-60%) 的储藏室 / 车间内进行储存和加工。

Wood-based materials should be stored, or processed, in a closed storage/workshop space with constant climatic conditions ( $T \geq 10^{\circ}\text{C}$  and at approx. 50-60% relative humidity).

如果相对湿度长期超过 60%，应打开包装塑料扎带。这可以防止板材由于吸湿导致厚度膨胀增加从而引起塑料扎带对顶部板材的表面和边缘造成可能的损害。

If the relative humidity permanently exceeds 60%, the plastic straps of the package should be opened. This prevents possible damage from the plastic straps to the surface or edging area of the top board due to increased thickness swelling of the boards.

储存和加工应该和最终的使用环境相呼应。

Storage and processing conditions should correspond to the climate of subsequent use.

为了确保最佳的平整储存，有必要在产品运输、储存和加工过程中避免以下消极影响。

To ensure optimal flat storage, it is necessary to avoid the following negative impact on the product during transport, storage and processing:

- 储存在靠近加热设备或其他热源的地方

Storage in the immediate proximity of heating devices or other sources of heat

- 直接暴露在热源和太阳光下 (室外 UV 灯)

Direct impact of heat radiation and direct sunlight (UV light outdoors)

- 随着空气湿度不断增加而引起的不均匀适应变化的环境中。

Uneven acclimatisation with increased air humidity variation

- 单板的储存，堆栈的顶部和底部板比堆栈内的板对变化的环境影响 (气候) 反应更快。

Storage of individual boards; the stack's top and bottom boards react faster to changing environmental influences (climate) than boards inside the stacks

### 3.2. 平衡调节 Conditioning

木质材料会因环境条件的变化而产生尺寸伸缩变化。因此，这类材料的储存和加工条件应尽可能与随后使用地点的气候环境相一致。在安装之前，爱格木质材料应当在接下来安装使用处的环境下平衡一段时间。建筑工地也必须同样遵守此类储存建议。木质材料必须首先在将要进行加工的室内气候条件下进行调节，使材料的温度与室温相对应。

Wood-based material reacts to changes in ambient conditions with dimensional movement. For this reason, storage and processing conditions for the elements should correspond as closely as possible to the climate at the subsequent place of use. Prior to installation, wood-based materials should be conditioned for an adequate period of time at the installation location under the conditions of subsequent use. Compliance with the storage recommendations is required on construction sites as well. Wood-based materials must first be conditioned in the room climate where the processing will take place, so that the temperature of the material corresponds to the room temperature.



### 3.3. 水平储存 Horizontal storage

应在具有承重和平整的地面上进行堆放 (见图 1)。托梁应具有均一的厚度且它们的长度应和板堆的宽度相对应。基础托梁之间的距离由板材厚度决定。

Stacking should be carried out on a load-bearing and level surface (see Fig. 1). Joists should have a uniform thickness and their length should correspond to the width of the board stack. The distance between the joists depends on the thickness of the boards.

板材厚度  $\geq 15$  mm : 托梁之间的距离至少为 800 mm。在任何情况下, 对于半幅面的板材 ( $l=2800$  mm) 应至少使用4根托梁。

Board thickness  $\geq 15$  mm: The distance must not be greater than 800 mm. In any case, at least 4 joists are recommended for half-format boards ( $l=2800$  mm).

板材厚度  $< 15$  mm : 托梁之间的距离应小于 800 mm。规则是 “距离 =  $50 \times$  板材厚度 (mm) ”。

Board thickness  $< 15$  mm: The distance should be less than 800 mm. As a rule of thumb, “distance =  $50 \times$  board thickness (mm)” can be used.

为了保护板材的表面, 两块板的花色面必须一直相对, 且 / 或必须使用

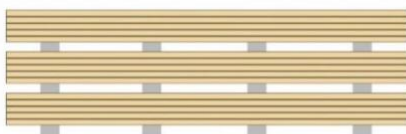
护板。如果堆栈最后用不锈钢带或塑料带扎紧, 应确保足够的边部保护。这可以通过特殊的纸板或使用护板来实现。在几层堆栈储存在彼此上下方的情况下, 托梁必须彼此上下呈垂直线状放置 (见图 2)。在相同规格的堆栈上应避免板材的突出。

To protect the board surfaces, always place the decorative tops of two boards against each other and/or use cover boards. If board stacks are subsequently fixed with steel or plastic straps, care must be taken to ensure adequate edge protection. This can be achieved with the help of special cardboard or by using protection boards. In the case of several stacks stored on top of each other, the joists must be placed in a vertical line underneath each other (see Fig. 2). Protruding boards in stacks of the same size should be avoided.

图 1 Figure 1



Right



Wrong



图 2 Figure 2

### 3.4. 垂直储存 Vertical storage

水平储存总是优于垂直储存因为其安全性及平整度更好。在垂直储存的情况下，应特别注意确保板材固定。可以通过封闭的储存架、储物室或货架来实现。储存间隔不应超过 500mm 的宽度。

Horizontal storage is always preferable to vertical storage because of its safety and better flatness. In the case of vertical storage, particular care must be taken to ensure that the boards are securely fixed. Adequate fixation can be achieved by means of closed storage racks, storerooms or shelves. The storage compartments should not exceed a width of 500 mm.

如果使用开放式储存架，接触面必须有最小约为 10° 的倾斜角度。另外，仅当具有相同规格的爱格木质板材才能储存在开放的储存架上 (图 3 和 4)。

If open storage racks are used, the contact surface must have a minimum inclination of approx. 10°. In addition, only same format boards should be stored in open storage locations (Fig. 3 and 4).

正确 Right

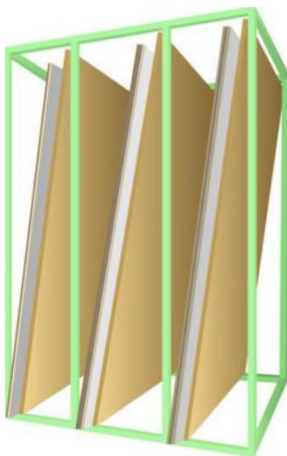


图 3 Figure 3

错误 Wrong

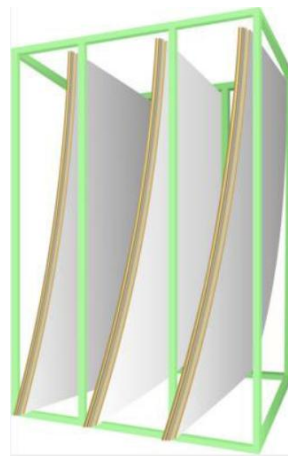


图 4 Figure 4

### 3.5. 操作 Handling

在去除包装后且在加工之前，应检查爱格木质产品可视的损坏。一般来说，考虑到板材可能具有锋利的边缘，所以，所有运输和 / 或操作板材的人员应穿戴个人安全防护设备 (如: 手套、安全靴和合适的工作服)。必须直接抬起板材 (见图 5)。始终不能通过其中一块板材来推或拉并摩擦到另一块板的花色面。

After removing the packaging and prior to processing, wood-based panels should be inspected for visible damage. As a general rule, all persons transporting and handling boards should wear personal protective equipment (PPE) such as gloves, safety shoes and suitable work clothing, given that the boards may have sharp edges. The boards must be lifted (see Fig. 5). The de-cor sides should never be pushed against one another or dragged over one another (see Fig. 6).

正确 Right

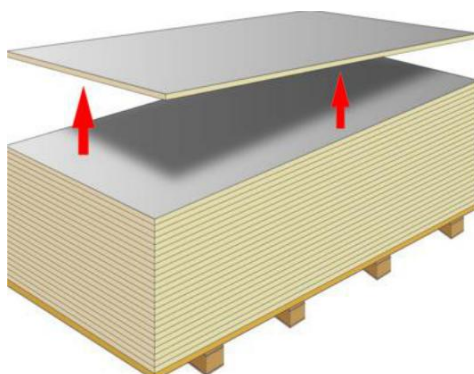


图 5 Figure 5

错误 Wrong

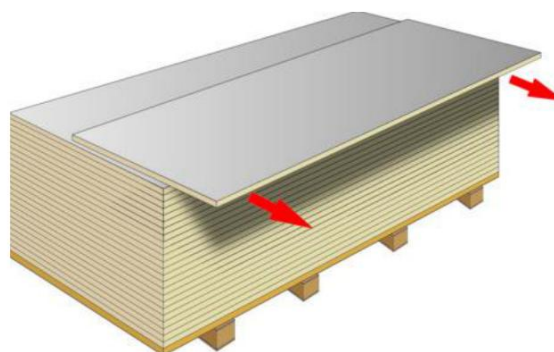


图 6 Figure 6

## 4. 刀具推荐 Tool recommendations

关于铣削、锯切和转孔的加工详细信息可以参考我们的刀具推荐信息。这些刀具建议是基于与知名刀具制造商合作通过各种系列的测试获得的最佳加工结果。

Detailed information regarding processing by milling, sawing and drilling can be found in the tool recommendations. These tool recommendations are based on various test series with the best machining results in cooperation with well-known tool manufacturers.

请从 [www.egger.com/downloads](http://www.egger.com/downloads) 中找到更多信息。

For more information, please visit [www.egger.com/downloads](http://www.egger.com/downloads)

## 5. 加工 Processing

### 5.1. 板材膨胀 Board expansion

尽管木质材料具有良好的尺寸稳定性，但周围环境条件的变化会导致材料尺寸发生变化。芯层材料中的木片和纤维方向决定了板材的生产或进给方向 (见图 7)。尺寸在纵向方向上的变化与横向方向上的变化不同。必须考虑建筑材料中材料尺寸的变化。

Notwithstanding the good dimensional stability of wood-based materials, changes in the ambient conditions can result in format changes. The orientation of the chips and fibres in the core material gives the board a production or running direction (see Fig. 7).

The format changes are different in the longitudinal direction than in the transverse direction. The format changes must be taken into account in the construction.

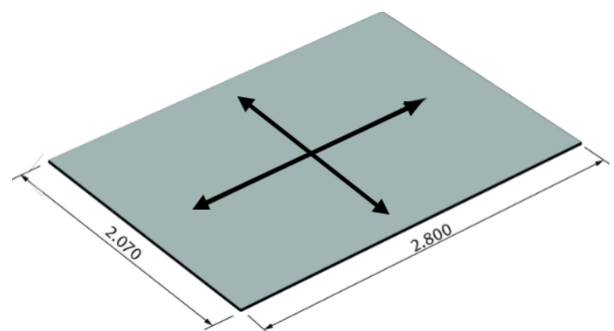


图7 Figure 7

对于木质材料，相对湿度变化10% (在20 %到80 %之间) 会导致板材湿度变化1.6 %。相对湿度的变化越大，可以预期的膨胀越大。因此，重要的是要事先在适当的房间中对板材进行调节，以避免由于板材湿度的巨大变化而导致更大的膨胀。下表显示了几种不同湿度变化条件下的尺寸变化。

For wood-based materials, a change in relative humidity of 10% (between 20% and 80%) can cause a change in board moisture of 1.6%. The greater the change in relative humidity, the more expansion can be expected. It is therefore important that the board is conditioned beforehand in the appropriate room climate to avoid greater expansion as a result of sizeable changes in board humidity. The table below shows the dimensional movement to be expected from several different humidity changes.

安装时的相对湿度 (%) Rel. humidity at installation (%)*	某个时刻的相对湿度 (%) Rel. humidity at time t (%)	尺寸变化 Dimensional movement (mm/m)
65	85	1.6
65	30	-1.9
30	85	3.5

\*温度为 20°C 时 At a temperature of 20 °C

板前后不同的气候条件也会导致板材翘曲或弯曲。因此，使用爱格木质材料作为墙板时应始终保持板背面足够的通风，以实现温度和湿度平衡或与环境相适应。

Different climatic conditions in front of and behind laminated boards can also lead to warping or curvature of the board. For this reason, wall cladding with EGGER wood-based materials should always be executed with sufficient rear ventilation, which enables temperature and moisture equalisation or acclimatisation.

生产方向只能根据产品尺寸来区分识别。木质和定向印刷花色例外。当使用切割成型的板材时，在安装过程中应确保生产方向始终匹配。考虑到切割成型的板相互混淆的风险，应在板材剩余物上标明机器进给方向。

The production direction of boards can often only be recognised from the production dimensions. Woodgrains and directionally printed decors constitute an exception. When working with cut-to-size boards, it is important to ensure that the production direction is always matched up during installation. In view of the risk of confusion in the case of cut-to-size boards, the running direction should be marked on board leftovers.

## 5.2. 切口 Cut-outs

加工之前，确保材料被安放到位，这样在锯切、铣削或钻孔作业就不会产生任何破坏。尤其，切口周围的窄板区在加工过程中如果不恰当的操作处理，会产生断裂或裂纹。板在切口时也应固定并保证安全，这样它们就不会以一种不受控制的方式断裂或脱落并因此造成人员伤亡或财产损失。

As a rule, before processing, it is important to ensure that the board is always securely in place so that no damage is caused by sawing, milling or drilling work. Especially narrow joining areas can break during machining due to improper storage. The board cut-outs must also be secured so that they cannot fall out or break in an uncontrolled manner and thus injure persons or cause other damage.



图 8 Figure 8

矩形切口应在边角处打磨半径，因为锋利的边角对材料有害，会导致开裂（见图8）。尤其对于橱柜背板、家具主体板、搁板等，这些地方由于经常暴露在干热的条件下，收缩应力会增加。当使用照明设备（内置照明）时，必须确保连续温度负荷不超过 50°C。

Rectangular cut-outs should be provided with a radius in the corners, as sharp-edged corners are detrimental to the material and lead to cracking (see Fig. 8). This is especially true for kitchen back walls, furniture bodies, shelves, etc., where increased shrinkage stress occurs due to frequent exposure to heat from drying. When using lighting (built-in spots), it must be ensured that a continuous temperature load of 50 °C is not exceeded.

为了获得干净、无裂纹的边缘，应使用 CNC 铣削机或手动铣削机对切口进行铣削。当使用锯子（例如台式圆锯）时，有可能在边缘处产生裂纹。这些情况会根据设备类型、锯片类型、锯齿等的不同而不同。在板材在使用过程中仅在一侧可见的情况下，可以将因锯切原因产生的裂纹置于不可见的背面。建议用砂纸或其他工具修整边缘，即所谓的“边缘裂缝”，以防止由于切屑脱落而导致缺口裂缝的产生并避免在处理过程中割伤。

For a clean, tear-free edge, the cut-out should be milled, preferably with a CNC router or a manual router. When using saws (e.g. bench circular saw), there is a risk that splinters can occur at the edging. These can vary depending on the machine, type of saw blade, saw tooth, etc. In the case of workpieces that are only visible on one side, it is possible to place the splinter that resulted from sawing on the non-visible rear side. Finishing the edges, known as “edge breaking” with sandpaper or other tools, is recommended to exclude notch cracks due to chipping and to avoid cut injuries during handling.

### 5.3. 封边 Edging

根据预期用途，木质材料配备了与所有装饰面匹配的封边带且这些封边带具有保护和装饰功能。作为爱格装饰材料的一部分，我们也提供装饰木质材料配套的封边带 (见图 9)。爱格提供不同材质的封边带，如ABS, PP, PMMA或PVC。 Depending on the intended use, wood-based materials are equipped with edging that provides the matching finish to all decorative coatings and take on a protective and design function. As part of the EGGER decor and material match, we also offer the matching edging for the decorative wood-based materials (see Fig. 9). EGGER edging is offered in various plastics such as ABS, PP, PMMA or PVC.



图9 Figure 9

封边通常是通过使用热熔胶技术的标准封边机或加工中心进行加工的。对于封边的应用，通过粘贴、修剪、铣削及采用刮刀和抛光棉处理。手动封边也可以使用施胶架或封边熨斗机来实现。

Edging is normally carried out with standard edging machines using hot-melt adhesive technology or with processing centres. For edge application, these are glued on, trimmed, milled and processed with draw blades and polishing mops. The manual application of edging is also possible using a gluing stand or edging press.

封边带背面附有胶黏剂底涂层，这对于完美粘合是必要的。该涂层已通过使用EVA、PA、APAO和PUR 热熔胶进行优化。白乳胶不能保证粘贴的效果。

The edging has an adhesion primer coating on the rear side, which is necessary for perfect bonding. This coating has been optimised for use with EVA, PA, APAO and PUR hot-melt adhesives. Bonding cannot be guaranteed with white glue.

像芯材一样，封边带材料必须事先在将要进行加工的房间环境中进行调节。

Like the core board, the edging material must be conditioned beforehand in the room climate where the processing will take place.

更多详细信息，请参阅爱格网站爱格封边带技术数据表或加工说明 [www.egger.com](http://www.egger.com)

Further information can be found in the data sheets or processing instructions for the edging at [www.egger.com](http://www.egger.com)

### 5.4. 切口/钻孔的密封 Sealing of cut-outs/drill holes

总的来说，用于桌面 / 台面、门板及面板等的爱格双饰面板都可以通过饰面层有效地保护着板材免受水分的浸入。然而，通过无保护措施的边缘 (如切口、转角接缝、斜接缝、背面边缘、钻孔、螺丝孔和固定装置处)，水分和潮气依然可以浸入基材。尤其在水平方向，必要的密封工作必须在最后安装时进行实施。爱格封边带 (热塑性封边带) 被用于可见切割边缘的密封。密封木质产品隐形切割边缘的最佳产品是密封条和自固化密封胶 (如硅胶、聚氨酯和丙烯酸等) (图 10)。当使用密封胶时，必须也要同时使用底涂剂；或者基于材料本身可以形成薄膜或清洁底涂剂的一种。

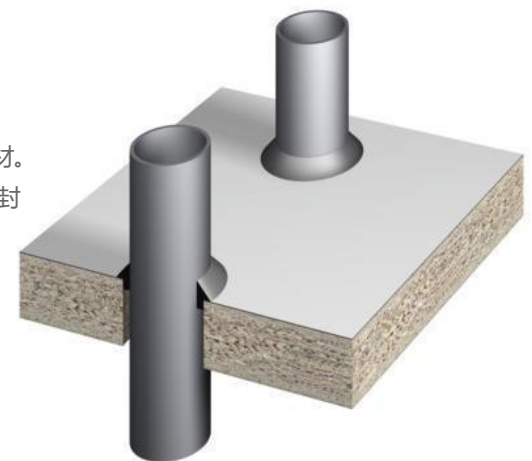


图10 Figure 10

In principle, Decorative Boards used as table/worktops, fronts, etc., are reliably protected against moisture penetration by the coating. Moisture and damp can still reach the core board, however, via unprotected edges such as cut-outs, corner joints, mitres, back edges, drill holes, screw holes and fasteners.

Especially in the case of horizontal surfaces, the necessary and final sealing work must always be carried out during final assembly. EGGER edges (thermoplastic edges) are used to seal visible cut edges. The best products for sealing hidden cut edges have been found to be sealing profiles and self-curing sealants, such as silicon rubber, polyurethane and acrylic (Fig. 10). When using sealants a primer also has to be applied; either one that forms a film or a cleaning primer depending on the material.

当使用这些材料时，必须认真遵守制造商的使用说明书!

You must follow the manufacturer's instructions carefully when using these materials!

在使用底涂剂时，必须清洁密封区域并必须遵守制造商规定的通风时间。涂抹密封胶，不留下任何缝隙或孔洞，然后用水和洗涤剂抹平滑。应遮住靠近接头的地方，防止表面变脏。任何通过该材料引出的管道或引线，应居中且距各边的最小距离为2到3毫米，并认真进行密封。It is absolutely essential that you clean the areas you are sealing and to allow the manufacturer's specified venting time when using primers. Apply the sealant leaving no gaps or holes and then smooth over with water and detergent. Areas near joints should be masked off to prevent the surface from becoming dirty. Any pipes or cables must be centred so that a minimum distance of 2 to 3 mm is maintained on all sides of the feed-through. Careful sealing is also required.

## 5.5. 粘合 Bonding

为了避免应力，只有经空气调节充分的木质板材才能粘接在一起并且仅在相同的移动方向上。胶合之前，板材表面要进行打磨、除尘、除油脂和污垢且当必要时要进行预处理。建议自行进行材料加工试验。请遵守胶水生产商的加工指南方针。

To avoid stress, only adequately conditioned wood-based materials should be bonded together and always only in the same running direction. Prior to bonding, the boards have to be sanded, free of dust, grease and dirt, and pre-treated as necessary. Bonding trials are recommended. Please observe the processing guidelines of the adhesive manufacturer.

### 5.5.1. 两块板的表面粘合 Surface bonding of two boards

两片大尺寸的爱格双饰面板的表面粘合需要特别的注意。因接合点会受应力的影响（如由于振动、撞击等），所以结合点必须通过机械式卡头来进行加强固定。两块饰面板粘合前，建议先用砂纸打磨，并清除油污和灰尘。根据应用区域的不同，可以使用 PUR 粘合剂或接触型粘合剂。以下粘合剂类型都可以使用：

Surface bonding of two coated Decorative Boards of large dimensions requires special precautions. Joints that are subject to major stress, for example due to vibrations, impacts, etc., must be reinforced by mechanical joints. Before bonding two coated boards, it is recommended to sand them first and clean any oil, grease or dust. Depending on the application, PUR adhesives or contact adhesives can be used. Following adhesives are possible:

- 2K-PUR-Adhesive 573.8 from Kleiberit
- Jowat 690.00 from Jowat

针对两块素板的粘合，也可以使用分散型胶黏剂，因为和饰面板相比，素板具有吸水性基层。可以使用的胶黏剂如下：

For bonding of two raw boards, dispersion adhesives can also be used, as these have an absorbent substrate compared to laminated boards. Possible adhesives are:

- Aquence KL 072 and Aquence KL 071/2 from Henkel
- PVAC adhesives from Kleiberit (e.g. 322.0 D2 surface glue)
- Jowacoll 103.10 from Jowat

但是，对于所有类型板的表面粘合，必须遵守胶黏剂制造商的说明。建议自行进行材料表面粘合试验。

It is important, however, to follow the adhesive manufacturer's instructions for all surface bonding and to consult the adhesive manufacturer. It is also advisable to carry out trial bonding.

### 5.5.2. 和其它材料间的粘合 Bonding with other materials

当将木基材料与其他材料（如金属和塑料）进行粘合时，应确保该类型胶黏剂适合粘合且不会侵蚀所用的材料。例如，应使用无溶剂和无硅添加的镜子粘合剂将木质材料粘合到镜子上。建议遵守胶黏剂制造商的说明，如果有不清楚的地方请咨询他们。还必须考虑到不同材料的不同膨胀特性。

When bonding wood-based materials with other materials such as metals and plastics, it is always important to ensure that the adhesive is suitable for the bonding and does not attack the materials in question. For example, a solvent-free and silicone-free mirror adhesive should be used for bonding wood materials to a mirror. It is recommended to follow the adhesive manufacturer's instructions and to consult them if anything is unclear. The different expansion behaviour of the different materials must also be taken into account.

### 5.6. 螺钉连接 Screw connection

如果配件、墙端压条等要附在木质材料表面，必须要确保在螺钉连接的区域表面进行预钻孔。钻孔的直径应比固定件的直径小 1 mm 来避免在材料中产生应力且能够将螺钉拧的足够紧。此外，可以使用自攻螺钉。对于水平表面，建议在上螺钉前用密封胶保护螺孔内部。

If fittings, wall end strips, etc., are fastened to wood-based material surfaces, the surface must be pre-drilled in the area of the screw connection. The drill holes should be 1 mm smaller than the screw diameter to avoid tension in the material and to be able to screw in the screws sufficiently tight. Alternatively, self-tapping screws can be used. With horizontal surfaces, we also recommend protecting the inside of the screw hole with sealant before screwing.

Joints that are subject to heavy loads, such as corner and body joints, can be strengthened by combining bonding and fasteners, shaped springs or grooves.

对于平行于板边或板材顶部或底部的钻孔，钻孔应距剩余板材任意一边的距离最小为 3 mm。

Note that a residual material thickness of 3 mm is taken into account for screw connections parallel to the edge or to the top or bottom of the board (see Fig. 12 and 13).

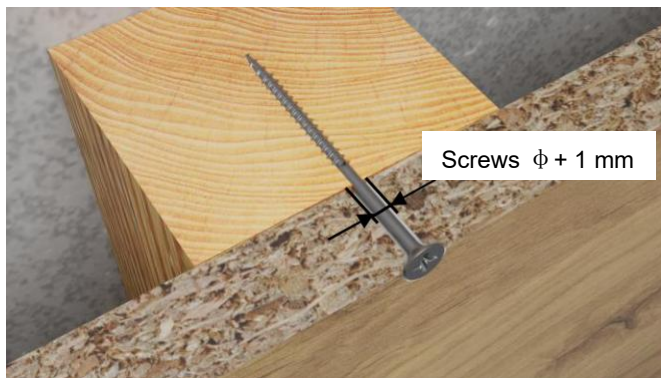


图 11 Figure 11



图 12 Figure 12

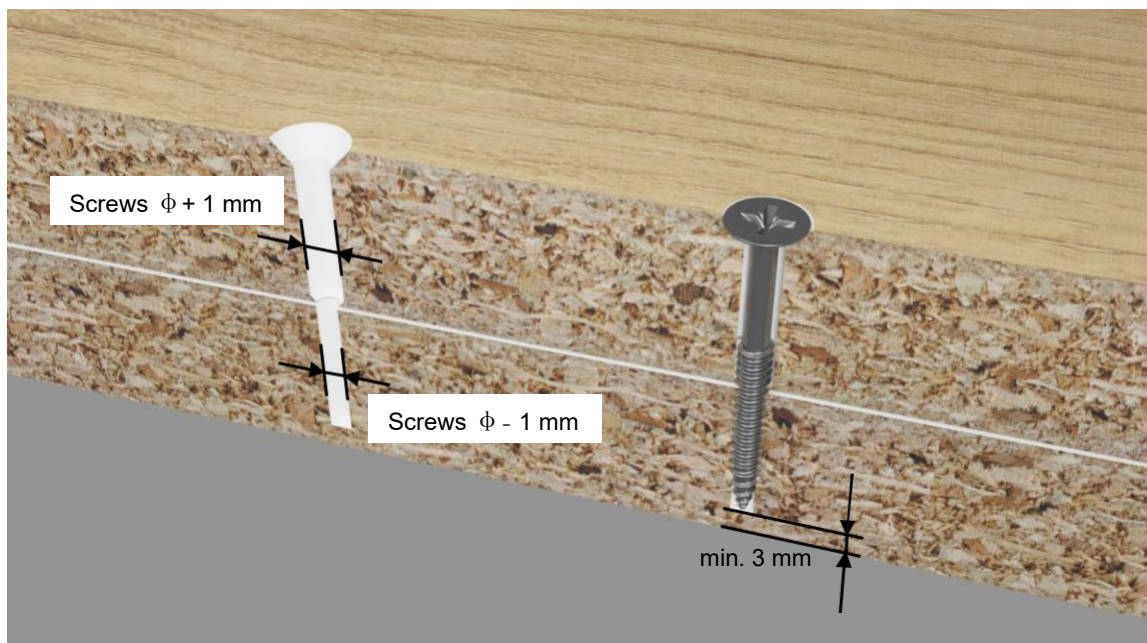


图 13 Figure 13

## 5.7. 平头螺钉连接 Flat screw connection

通孔连接的平头螺钉必须有足够的间隙，以补偿温度和湿度波动造成的尺寸移动。这样可以避免在天气变化时因胀缩运动而产生的张力。为此，在单个元素上进行浮点和定点的应用。

Flat screw connections with trough holes must have sufficient clearance to compensate for the dimensional movement resulting from temperature and humidity fluctuations. In this way, tension due to the dilation and shrinking movement resulting from changing climate conditions can be avoided. Floating points and a fixed point are implemented on the individual elements for this purpose.

当使用埋头螺钉将两块板钉在一起时，在拧入螺丝钉前，建议先用埋头孔钻打个埋头孔。这样可以确保螺钉周围的饰面层不被损坏。待固定的板应有一个比螺钉直径大 1mm 的孔，另一块板应有一个比螺钉小 1mm 的孔，以便将螺钉拧入 (图 13)。

When screwing two boards together using countersunk screws, it is recommended to countersink the screw holes with a countersink before screwing in the screws. This ensures that the coating of the board around the screw is not damaged. The board to be fixed should have a hole larger by 1 mm, the other should have a hole smaller by 1 mm, so that the screw can be screwed in (Fig. 13).

### 5.7.1. 定点 Fixed points

定点的作用是均匀分布膨胀运动，并应尽可能位于中心位置。钻孔直径等于紧固件的直径 (图 14)。

The fixed point serves to evenly distribute the expansion play and should be positioned as centrally as possible. The drill hole diameter is the same as the diameter of the fastener (see Fig. 14).

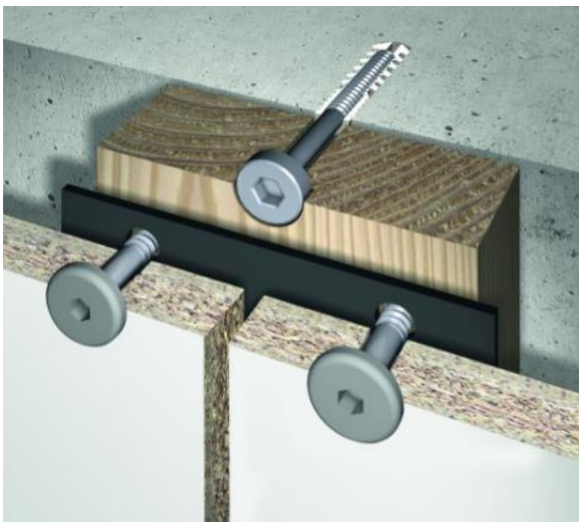


图 14 Figure 14



图 15 Figure 15

### 5.7.2. 浮点 Sliding points

浮点钻孔直径应比紧固件大 (见图 15)。钻孔要用螺钉头盖住。根据定点到板边的最大距离确定所需的伸缩间隙。长度每增加 1m，浮点钻孔的直径就要增加 2 毫米。在任何情况下，螺丝钉都要处于转孔的中心。有必要，可通过使用合适的钻具来确保这一点。

The drill hole diameter of the sliding points should be larger than the fastener (see Fig. 15). The drill hole should be covered by the head of the screw. The required expansion play is established based on the largest distance of the fixed point to the board edge. The floating point drill hole diameter must be increased by 2 mm for every metre of length. In any case, the screw must be positioned exactly in the centre of the drill hole. If necessary, this can be ensured by using suitable drilling jigs.

必要时应使用垫圈。在图中，EPDM (三元乙丙橡胶) 密封带应用于木制结构件来防潮。EPDM 代表乙丙二烯单体。EPDM 非常耐紫外线、臭氧和其他大气影响。

When necessary, use washers for the construction. In the figures, an EPDM sealing tape has been applied to the wooden sub-structure for protection against moisture. EPDM is very resistant to UV, ozone and other atmospheric influences.

### 5.8. 水平接缝和板接缝 Horizontal joints and board joints

爱格木质产品的水平转角接缝是通过圆台锯斜切或数控加工中心铣削设备和 / 或手持槽刨机借助辅助模板加工制成的。然后用各种五金件或通过胶黏剂重新连接 (图 17 和 18)。如果是暴露在潮湿的环境中的水平接缝, 请注意, 没有封边带保护的板的零件和对接接缝应进行密封。开放的接头或对接接缝会导致湿气渗入板内且会导致板材厚度膨胀。爱格密封剂产品 (图 16) – 可以阻止水分和其它液体的浸入且耐清洁剂、防水、耐油脂和油类且能提供他4 中不同的颜色 – 非常适合密封板接缝。更多详细信息, 请参阅技术信息单页 “**转角接缝用爱格密封剂**”。

Horizontal corner joints of EGGER wood-based materials are made by mitre cuts on circular table saws or by milling by means of CNC routers or manual routers with the aid of templates. The boards are then re-joined with various hardware or by bonding (Fig. 17 and 18). In the case of a horizontal joint, which is also exposed to humidity, please note that the parts and butt joints of the boards that are not protected by plastic edging should be sealed. Open joints or butt joints lead to moisture penetration into the board and to thickness swelling. The product EGGER Sealing (Fig. 16) – which prevents the penetration of moisture and other liquids, is resistant to cleaning agents, water, greases and oils and, is available in four different colours – is suitable for sealing the board joint. Detailed information can be found in the technical leaflet “**EGGER seal-ing for corner joints**”.



图 16 Figure 17

此外, 也可使用金属压条接缝 (图 19)。这些压条很容易安装, 但在视觉上令人不舒服, 因为那会破坏表面平整度, 因此, 很难保持清洁。Alternatively, metal joining profiles can also be used (see Fig. 19). The profiles are easy to handle but visually rather disturbing as they interrupt the even surface and thus make cleaning more difficult.

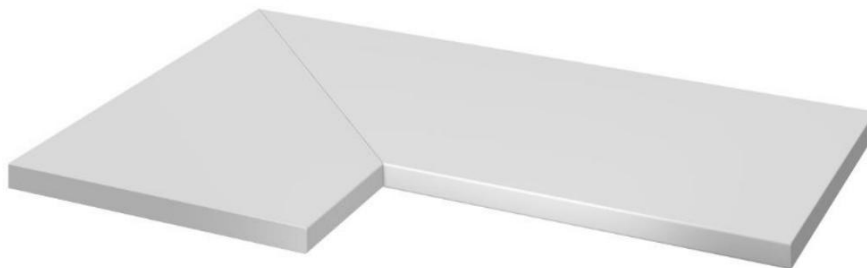


图 17 Figure 17

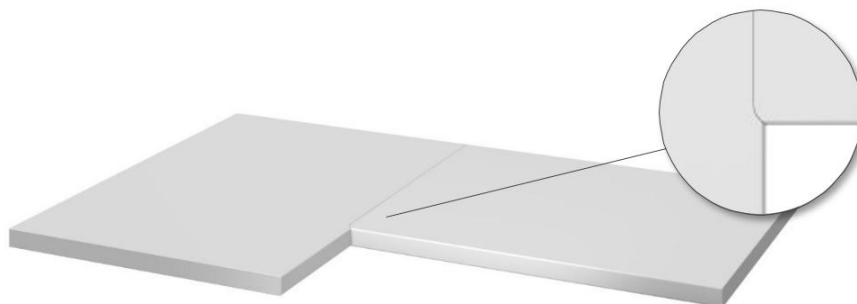


Figure 18



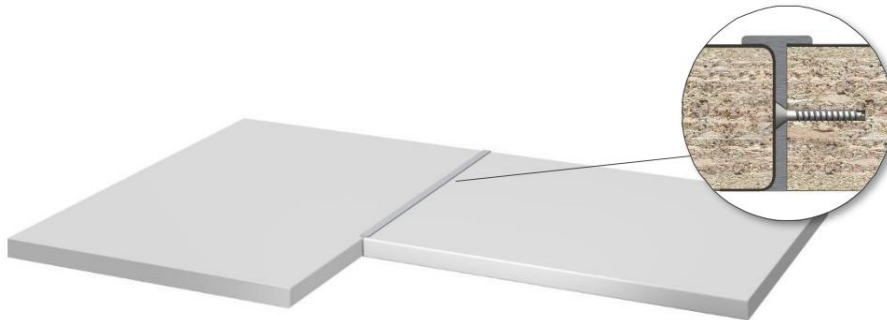


图 19 Figure 19

### 5.9. 上漆 Lacquering

对于上漆，建议使用具有上漆级饰面纸的爱格双饰面板。上漆级双饰面板具有一种高质量的，可随时上漆的饰面，这种饰面为中密度纤维板、爱格刨花板或超轻板的后续上漆提供了出色的表面准备。为了达到完美的上漆效果，需要确保板表面没有灰尘和油脂。必须遵循涂料制造商的加工说明。

For lacquering, it is recommended to use an EGGER board faced with painting grade paper. Painting grade is a high-quality, ready-to-paint coating that provides an excellent surface preparation for subsequent painting on MDF, chipboard or lightweight boards. For perfect painting of the board, you only have to make sure that the board is free of dust and grease. It is essential to follow the processing instructions of the paint manufacturer.

### 5.10. 固定件 Fittings

当在木质材料表面安装固定件时，必须遵守以下几点：

The following points must be observed when placing fittings on wood-based materials:

- 将拉手或类似的东西拧入板材表面时，应尽可能均匀地拧紧，但不要太紧，否则会在板材上产生压痕(图 20)。  
Handles or similar, which are screwed into the surface of the board, should be tightened as evenly as possible and not too tightly, otherwise indentations may occur in the boards (Fig. 20).
- 如果板上有盲孔(图 21)，请确保保留 3mm 的残余厚度。  
In the case of blind holes in the board (Fig. 21), make sure that a residual thickness of 3 mm is maintained.

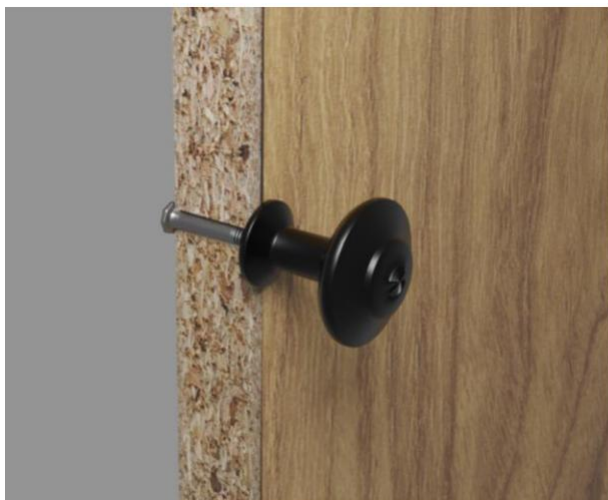


图 20 Figure 20



图 21 Figure 21

### 5.11. 素板深加工 Further processing of the raw board

对素板进行深加工处理时，应确保素板无灰尘、油脂和表面机械损伤。应特别注意泄漏的液体物质。这些会被素板吸收，导致板材不均匀膨胀。素板的吸湿膨胀将导致深加工的板不合格。

For further processing of the raw board, make sure that the board is free of dust, grease and mechanical surface damage. Pay special attention to leaked liquid substances. These are absorbed by the raw board and lead to uneven swelling of the board. Swelling on the board causes non-conforming further processing of the raw board.

分散型胶粘剂可用于将防火板粘合到素板上。适用的粘合剂是汉高的Aquence KL 072和Aquence KL 071/2 或 Kleiberit的PVAC胶黏剂。

A dispersion adhesive can be used for gluing laminate to the raw board. Possible adhesives are Aquence KL 072 and Aquence KL 071/2 from Henkel or PVAC adhesives from Kleiberit.

## 6. 应用 Applications

由于其日常使用中的坚固性和适用性，爱格木质材料特别适合于室内墙板的应用。我们建议此种应用的板厚最小为8毫米。在应用作为护墙板之前，底层结构应完全干燥。时刻确保板背面通风或使板充分适应当前环境。材料不应暴露在滞留的水分中。所有要连接在一起的板材必须遵循相同的生产方向。

Thanks to their robustness and suitability for everyday use, wood-based materials are particularly well suited for use as interior wall cladding. We recommend a minimum board thickness of 8 mm for such applications. The substrate should be completely dry before applying the cladding. Always ensure sufficient rear ventilation or acclimatisation of the boards. The material may not be exposed to trapped moisture. All parts to be joined together must follow the same production direction.

### 6.1. 墙板 Wall cladding

#### 6.1.1. 底层结构和背面通风 Substructure and rear ventilation

木质材料应固定在坚固、耐腐蚀和压入式连接的底层结构上，以安全地支撑墙板的重量并确保墙板背后时刻通风(见图 22)。在干式施工应用中，底层结构的连接物和木质材料必须固定到木钉框架上。

Wood-based materials must be attached to a stable, corrosion-resistant and force-fit substructure that securely supports the weight of the wall cladding and ensures ventilation behind the elements (see Fig. 22). In dry construction applications, the attachment of the substructure and the wood-based material must be anchored to the stud framing.

紧固件的选择必须根据底层结构和墙板的重量进行调整。元件前后不同的环境条件会导致翘曲。因此，木质材料墙板的安装必须始终为板后部提供足够的通风，从而使温度和湿度平衡。通风装置必须朝向房间一侧。

The selection of the fasteners has to be tailored to the substructure and the weight of the wall cladding. Different climate conditions in front of and behind the elements can lead to warping. It is therefore essential that wood-based material wall cladding installations always make provision for adequate ventilation to the rear of the boards, which allows temperature and humidity to equalise. Ventilation must be towards the room side.

若无背面通风或背面通风间隙小于 2 cm，墙体或灰泥等吸水性矿物基材必须进行防水涂料、弹性阻隔面料进行预处理。

If there is no rear ventilation or a rear ventilation gap < 2 cm, absorbent mineral substrates such as walls or the plaster must be pre-treated with waterproof, elastic barriers.

这些隔层面料通常是涂饰的，可以防止水渗透到砖石中，这对于在潮湿的房间中应用是必不可少的。

These barriers are generally painted on and prevent the penetration of water into the masonry, which is essential for application in a humid room.

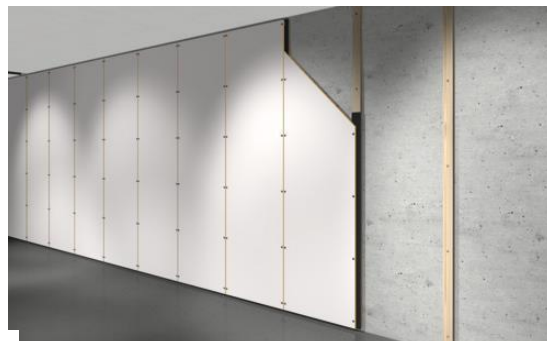


图 22 Figure 22

垂直板条通常允许空气流通。当底层结构水平布置时，适当的结构必须确保提供足够的通风。底层结构应垂直以使整个面板表面无应力。适合的底层结构包括垂直的木条，铝架或木质材料。

Vertical battens generally permit air circulation. Where substructures are arranged horizontally, an appropriate construction must ensure that adequate ventilation is provided. The substructure should be vertically plumb to allow tension-free mounting full surface. Suitable substructures include vertical strips of wood, aluminium or wood-based materials.

板条或底层结构的最大间距取决于所选的木质材料厚度。重要的是要确保进风口和出风口保持畅通无阻，以免空气流通受到阻碍。还要确保底部结构板表面的含水率与装饰墙板的含水率没有显著差异。

The maximum spacing of the battens or the substructure depends on the wood-based material thickness used. It is important to ensure that air inlet and outlet areas remain unobstructed so that air circulation is not impeded. Also ensure that the moisture of the surface to be panelled does not differ significantly from the moisture of the finished component.

以下是有区别的：

The following are differentiated:

- 可视机械固定安装 visible mechanical fastening
- 隐形机械固定安装 concealed mechanical fastening
- 隐形胶固定安装 concealed glued fastening

### 6.1.2. 可视机械固定 Visible mechanical fastening

固定是通过螺钉或铆钉在底层结构上完成的。必须充分考虑足够的膨胀间隙和浮点和定点的正确定位 (见图 14 和 15)。当使用木材作为基层结构时，必须使用EPDM (三元乙丙橡胶) 带进行解耦。

Fastening is done via screws or rivets on the substructure. A sufficient expansion play and the right positioning of floating and fixed points must be taken into account (see Fig. 14 and 15). An EPDM tape must be used for decoupling when using wood as substructure.

### 6.1.3. 隐形机械固定 Concealed mechanical fastening

通过悬浮式隐形固定的木质材料可以直接拆卸，比可视的固定方法更美观。拆卸这些板子既快捷又简单。很容易在安装部件后面安装电缆和管道。根据所选择的固定系统，另一个优点是元件可以在以后进行调整。可实现部件的无应力安装。对于所有涉及悬挂的安装方法，必须留有足够的空间来升降部件。这个间距或“悬挂间隙”将作为阴影空白部分保持可见。

The concealed fastening of wood-based panels by hanging permits straightforward disassembly and appears more visually appealing in comparison to visible fastening methods. Removing the boards is quick and simple. Cables and pipework installed behind the elements are easy to reach. Depending on the chosen fastening system, another advantage is that the elements can be adjusted later on. Tension-free mounting of the elements is also possible. For all fastening methods that involve hanging, sufficient space must be allowed to raise and lower the elements. This air space or “hanging space” remains visible as a shadow gap.



图 23 Figure 23

## 通过组合扣条悬挂安装

### Hanging by means of profile strips

对于这种安装方法，在水平底层结构中切割槽以扣住附着在墙板上的缩缘导轨。为了便于安装，缩缘导轨上的榫舌应比槽薄。木质材料元件上的缩缘导轨不应超过槽元件的整个宽度，缩缘导轨应是间歇性的，以允许垂直方向空气流通。可以使用现成的胶合板或金属Z型型材制成的缩缘导轨。如果薄型木质材料元件不能通过螺钉实现安全安装连接，也可以额外施胶固定。

For this fastening method, a groove is cut into the horizontal substructure to hold the rebate rail attached to the wall element. For ease of fitting, the tongue of the rebate rail should be thinner than the groove. The rebate rail on the wood-based panels should not extend across the entire element width, but should be interrupted to allow vertical air circulation. Rebate rails made of plywood or metal Z-profiles can be readily used. If it is not possible to securely screw thin wood-based panels, they can also be glued.

## 通过金属五金件安装

### Hanging by means of metal hardware

还可以使用金属五金件系统来安装墙板部件(见图 23)。选择的系统必须根据制造商的建议来使用，以确保安全安装。

Systems with metal hardware are also offered for mounting wall elements (Fig. 23). The chosen system must be used according to the manufacturer's recommendations to ensure secure installation.

### 6.1.4. 隐形施胶安装 Non-visible glued fastening

木质材料也可以通过粘合剂系统将板粘贴到底层结构上。底层结构系统被固定到墙面上(图 24)。当使用木板作为底层结构时，有必要使用底涂剂作为第一步，以确保安全的附着力和隔离潮气。

The fastening of wood-based panels can also be carried out by bonding to a substructure. The substructure system is force-locked to the wall (Fig. 24). When using wood as a substructure, it is necessary to apply a primer as a preliminary step to ensure secure adhesion and moisture decoupling.

遵守胶水厂家的加工说明。

Please observe the processing instructions of the adhesive manufacturer.



图 24 Figure 24

## 6.2. 家具门板 Furniture doors

当使用木质材料作为家具门时 (见图 25), 请注意以下几点:

When using wood-based materials as furniture doors (see Fig. 25), please note the following:

- 如果门板前后气候条件不同, 可导致门板翘曲。  
The board may warp if the front and back of the door have different climatic conditions.
- 铰链的数量取决于铰链的类型、门板尺寸以及门板的重量。使用铰链制造商提供的信息来计算铰链的数量和正确的定位。例如, 可从 Blum (百隆), Hettich (海蒂诗) 或 Häfele (海福乐) 获得合适的铰链。  
The number of hinges depends on the hinge type, the dimensions as well as the weight of the door. Use the information provided by hinge manufacturers to calculate the number of hinges and the correct positioning. Suitable hinges are available from Blum, Hettich or Häfele, for example.
- 由于门板纵向变化与横向变化是不同的, 因此建议要始终从板的同一方向上生产门扇。  
Since format changes in the longitudinal direction are different from those in the transverse direction, it is advisable to always produce door leaves from the board in the same direction



图 25 Figure 25 (百隆 BLUM)

## 7. 推荐的清洁方法及用量 Recommendations for cleaning and use

一般来说, 如茶水、咖啡和白酒等污渍和溢出物应立即清理, 因为如果任由它们风干, 清理的工作量会增加。当有必要时, 应使用温和的清洁剂。清洗剂必须不能含有任何研磨性成分, 因为它们可能会对光泽度产生不利的影响或划伤表面。因为由各种不同的物质引起的轻的、新鲜的污垢到由各种物质引起的重的、顽固的污垢都是可能发生的, 适当的清洁方式是很重要的。

As a general rule, stains and spilled substances such as tea, coffee and wine, etc., should be cleaned up immediately, as the cleaning effort increases if they are left to dry. When cleaning is necessary, mild agents should be used. Cleaning agents must not contain any abrasive components, as they may adversely affect the gloss level or scratch the surface. Since everything from light and fresh soiling to heavy and stubborn dirt caused by various substances is possible, proper cleaning is important.

**日常应用时请务必参照如下的说明:**

**The following information should be observed for daily use:**



将燃烧的香烟放在复合防火板表面会损坏表面。  
Placing burning cigarettes on Decorative Boards causes surface damage.

**请务必使用烟灰缸**  
**Always use an ashtray.**



爱格双饰面板表面不应被用作切割的表面，因为这也会在高耐受性的复合防火板表面留下切痕。  
In general, Decorative Boards should not be used as cutting surfaces, as knife cuts leave cut marks even on resistant surfaces.

**请务必使用砧板。**  
**Always use a chopping board.**



应避免将直接从铁架或烤箱热的烹饪餐具（如炖锅和煎锅）放置在复合防火板产品表面，依据不同的热度产品表面的光泽度可能会产生变化或着表面可能会受损。  
Placing hot cookware such as pots, pans, etc., as well as continuous heat sources such as a laptop on Decorative Boards should be avoided; depending on the heat exposure, a change in gloss level or surface damage may occur.

**请务必使用隔热装置。**  
**Always use heat protection.**



经溢出的液体应及时清除，因为某些物质成分暴露时间过长会影响复合防火板产品表面的光泽程度。尤其是产品切口和拼接处，溢出的液体必须迅速彻底的清理干净。

**Spilled liquids should always be cleaned up immediately**, since longer exposure times of certain substances may affect the gloss level of Decorative Boards. Especially in the areas around cut-outs and joints, spilled liquids should always be cleaned up quickly and thoroughly.

这些建议特别适用于与深色花色相结合的 哑光复表面。此种表面具有迷人的外观和触感，但会使产品表面的使用痕迹显得明显。These recommendations apply in particular to matt surfaces in combination with dark decors, which are captivating in their look and feel, but make traces of use appear more pronounced.

更多信息，请访问网站：[www.egger.com/downloads](http://www.egger.com/downloads)  
For more information, please visit [www.egger.com/downloads](http://www.egger.com/downloads)

## 8. 废弃处理 Disposal

建筑工地上的任何爱格木质材料残留物，以及因拆除产生的残留物，都应主要用来回收。如果这些回收是不可实现的，它们应被送往能源回收处而不是填埋。然而，对于燃烧，应该注意的是，与实木相比，木质材料由于其成分（如胶水等）会产生额外的排放物，这可能对环境有害，这就是为什么建议使用适当的过滤系统进行能量回收。根据欧洲废物目录的废物代码为：

170201/030105

Any residues of wood-based materials that accumulate on the construction site, as well as those from demolition measures, should primarily be recycled. If this is not possible, they must be sent for energy recovery instead of being sent to landfill. For combustion, however, it should be noted that wood-based materials generate additional emissions compared to solid wood due to their ingredients such as glue, etc., which could be harmful to the environment, which is why appropriate filter systems are recommended for energy recovery. Waste code according to European waste catalogue: 170201/030105.

必须遵守各个国家关于废物处置的具体法律条文和条例。

The country-specific laws and regulations on disposal must always be observed.

**临时说明**

**Provisional notice:**

这些加工说明是基于现有的最佳资料 and 经严格评估后编写的。数据依据实践经验和室内测试并符合我们目前的知识水平。该文件仅供参考，不作为产品特性或特殊用途适用性的担保。我们对任何错误、标准中的错误或印刷错误概不承担任何责任。另外，由于爱格木质产品的持续开发、相关产品标准以及法律文件的变更都可能产生技术层面的修改。因此，该文件内容不应被视为使用说明或法律约束文件。适用于我们的一般条款和条件。

These processing instructions were prepared based on the best available information and with due diligence. We accept no liability for any mistakes, errors in standards, or printing errors. In addition, technical changes can result from the continuous further development of EGGER wood-based materials, tool technology and changes to standards and documents of public law. Therefore, the content of these processing instructions cannot serve as a legally binding base

